

WISPEED



Non contractual photo

Electric Scooter WISPEEDSUVPILOT 150

USER MANUAL

Original

FR

Retrouvez toutes les dernières versions des notices MULTI LANGUES des produits WISPEED sur notre site internet www.wispeed.net **en flashant le QR code !**

EN

Find all the latest versions of the MULTI LANGUAGE instructions for WISPEED products on our website www.wispeed.net **by flashing the QR code !**

ES

Encuentre todas las últimas versiones de las instrucciones MULTI IDIOMA para productos WISPEED en nuestro sitio web www.wispeed.net **mostrando el código QR !**

PT

Encontre todas as versões mais recentes das instruções MULTI LANGUAGE para produtos WISPEED no nosso site www.wispeed.net **piscando o código QR !**

NL

Vind de nieuwste versies van de MEERTALIGE instructies voor WISPEED-producten op onze website www.wispeed.net **door de QR-code te knippen !**

PL

Znajdź wszystkie najnowsze wersje instrukcji MULTI LANGUAGE dla produktów WISPEED na naszej stronie internetowej www.wispeed.net **skanując kod QR!**



READ BEFORE ANY USE

IMPORTANT: Please read carefully and keep for future reference.

This product is considered a class 2 light personal electric vehicle (PLEV) according to EN17128.

WARNING: Never use this vehicle outside of areas authorized by regulations.

Before using your scooter, you must read the precautions for use and safety instructions. These are defined by clearly identifiable pictograms.

The use of your scooter is subject to the legislation in force in your country. Please inquire with the relevant authorities.

Any recommendation (or lack of recommendation) in this manual cannot in any way be considered as a transposition of the legislation in force.

1- Precautions for use and safety instructions

1.1 General

- Read these instructions carefully
- Save these instructions
- Follow all instructions
- Heed the warnings
- Do not attempt to disassemble the device or modify it, otherwise it will no longer be covered by the warranty.
- Refer to qualified personnel for any repairs

1.2 Safety instructions & precautions for use



- The use of the scooter is prohibited for children under 14 years of age. The maximum age to use the scooter is 75 years old. The minimum height for using the scooter is 155cm. The maximum height to use the scooter is 210vsmr.
- Avoid high traffic areas and/or congested areas.
- The use of your scooter is not suitable for pregnant women.
- This device can be used by children from 14 years of age under adult supervision, and by people with reduced physical, sensory or mental capabilities or lack of experience or knowledge provided they are properly monitored or have received from a person responsible for their safety of

prior instructions relating to the use of the device in complete safety and that all risks involved are understood.

- Children should not play with the device. This scooter is not a toy. The device is not intended for acrobatic use.
- Check regularly that your scooter is in good condition, read this manual carefully and make sure you understand all product information before using it.



- Cleaning and maintenance of the device by the user must not be carried out by children.
- Before each use, check the general condition of your scooter (condition of tires, tire inflation, brakes, battery, headlight, rear light)
- Your scooter has parts that are subject to heating, such as the brake drum and the wheels. It is prohibited to touch these elements less than one hour after using your scooter. Before each use, remove any sharp edges previously caused by use.



- It is strongly recommended that all users wear adequate protection when using your scooter to avoid any bodily harm in the event of a fall: closed shoes, helmet, gloves, knee pads, elbow pads.



- Fully charge the battery of your scooter before first use.



- Do not use your scooter in busy areas during your first use. A time of adaptation is necessary to master the product.



- Use on public roads is regulated. You must use the cycle paths. In the absence of these, you can drive exclusively on roads limited to 50 km/h.



- Outside urban areas, you can only ride on greenways and cycle paths.
- On sidewalks, pedestrian zones, within buildings or any other place dedicated to pedestrians, you must move with your scooter held in your hand.



- Check with local authorities for possible traffic restrictions..
- Be sure to respect road markings, signage and the highway code. Let pedestrians pass when riding your scooter.



- Do not hesitate to announce your presence to other users via the buzzer (bell).



- When riding with other people, maintain a safe distance of at least 6 meters between you to limit the risk of collisions.

- In all circumstances, ensure your safety and that of other users.
- Adapt your speed (and your safety distance) according to your environment so you can stop your scooter at any time.



- Do not start or stop suddenly.
- Take care always be visible to everyone. At night or as soon as the light drops, turn on your headlight, your taillight, wear a vest (or other retro-reflective equipment)



- Always keep your hands on the handlebars when using your scooter. The use of a smartphone or any other object while driving is prohibited.





- The use of headphones or headphones while riding is prohibited.
- It is forbidden to ride with several people on your scooter.
- The maximum weight supported by the scooter is 120kg.
- The minimum weight to use the scooter is 50kg.
- Failure to follow these weight recommendations will impair the acceleration and braking performance of your scooter and may put you in danger by reducing its ability to safely decelerate or stop.
- Any load attached to the handlebars will affect the stability of the vehicle.
- It is prohibited to use accessories or additional elements not approved by the manufacturer.



- Keep your body balanced when making turns to avoid falling due to shifting your center of gravity or high speeds.
- Always keep your feet on the footrest when riding.
- A collision or fall can result in death or serious injury. Reading the user manual is necessary to know how your scooter works and to control your vehicle in all circumstances.
- Do not jump over obstacles with your scooter.



- Do not jump on the deck of your scooter.
- Avoid driving on roads littered with scattered objects, such as branches, trash or small stones;
- Do not ride your scooter on roads with obstacles or on slippery roads where there is a risk of loss of grip such as snow, ice or water. This could

cause a loss of grip and result in personal injury and property damage.

- Braking distances are significantly extended in the event of wet roads, rainy weather or the presence of water on the road.
- Avoid riding on steep slopes. Do not use your scooter on slopes that are too steep, the maximum angle of inclination is 20%. Gaining speed on a descent that is too steep can cause the motor and battery to overheat and reduce your ability to safely brake.
- Adopt all necessary safety precautions when learning to use your scooter. Remember that you can be injured when losing control, in collisions or falling from your scooter.
- If a traffic accident occurs while riding your scooter, remain calm, secure the scene and wait for competent personnel who will handle the situation responsibly and legally.
- Do not use your scooter in an unsafe environment, i.e. in places where there are flammable products, steam, liquids, dust or fibers which could cause a fire or explosion.
- The plastic bags supplied with the scooter are not toys and should not be left within reach of children.
- The rear mudguard should not be used as a brake. You risk damaging your scooter without being able to lower your speed.
- Always fold the kickstand before use.
- After use, stabilize the scooter by unfolding the kickstand on flat ground.



- It is mandatory to wear suitable, closed shoes for the entire time you use your scooter.
- The external battery charger flex cable cannot be replaced. If the cord is damaged, the transformer should be discarded.
- Be sure to unplug the mains plug before disconnecting the power cable.
- **Your scooter cannot be turned on as long as it is plugged into its mains adapter and it is itself plugged into the mains.**
- Use under the influence of alcohol and/or drugs is prohibited.
- Being a motorized vehicle, specific Civil Liability insurance is mandatory for driving.
- **WARNING** As with any vehicle, your scooter contains mechanical components subject to high stress and wear. Different materials and components may react differently to wear or fatigue. If the expected lifespan of a component is exceeded, it may suddenly break and risk injury to the user. Cracks, scratches, and discoloration in high-stress areas indicate that the component has exceeded its lifespan and should be replaced.
- Driving in the city involves crossing many obstacles, such as sidewalks or steps. Jumping obstacles is prohibited. It is important to anticipate and adapt your trajectory and speed to those of a pedestrian when living with other users. It is strongly recommended to get out of the vehicle when



these obstacles become dangerous due to their shape, their height or the risk of skidding that they present.

- For more information regarding the battery charging procedure, please go to §5.1 “Charging the battery”.
- Keep the printed instructions for future reference and read them carefully before use

Logicom disclaims all liability in the event of bodily injury and/or material damage attributable to use of the product not in accordance with the instructions for use.



- If your scooter shuts down due to overheating, place it in a cool, dry place and wait for the battery and motor to cool before using it again.
- **CAUTION:** To recharge the battery, use only the removable power supply supplied with the device. Do not use any power supply or electrical device other than that supplied with the device.



0-45°

- The electrical outlet to which the device is connected must be installed near the equipment and must always be easily accessible. Prevent someone from walking on the electrical cable (or stumble because of the latter)
- Battery life largely depends on how you use it. Do not expose the battery to temperatures below 0°C or above 45°C. Its operation could be impaired.

- Do not leave the battery on prolonged charge when not in use.
- Do not attempt to disassemble this product to access the battery. The battery is non-removable.
- Do not disassemble, open or shred battery cells. Do not throw the battery into fire or water. Do not charge the battery if the ambient temperature exceeds 45°C.
- If the battery leaks, take care not to let the liquid come into contact with the skin or eyes; if this occurs, wash with plenty of water and consult a doctor.
- For any repairs or replacement of the battery, contact a qualified technician.
- Dispose of battery and equipment separately. Do not dispose of the battery with household waste. For any information regarding the recycling of the battery and the scooter, please contact your municipality, your local recycling center or the point of sale from which you purchased this product.





2- General presentation of the product

2.1 About the WISPEED SUVPILOT 150

The WISPEED SUVPILOT 150 is a two-wheeled electric scooter. Its simple operation, its accessible controls, its resistance to splashes and its respect for the environment make it an adequate means of transport in an urban environment.



2.2 Package contents

- 1x Electric Scooter WISPEED SUVPILOT 150
- 1x Mains Charger  (Model: FY-4202000 Shenzhen Fuyuan Power Co., Ltd) (Input: 100-240 VAC, 2.5A, 50/60 HZ; Output: 42.0 VDC, 2A)
- 1x User Manual 
- 1x Hex key 
- 1x Inflation nozzle 
- 6x Screws 

WARNING !: In order to best protect your scooter during possible after-sales service, we strongly recommend that you keep the packaging. This can help you avoid damage during transport which would not be taken into account in the guarantee.

2.3 Description of the scooter

1. L/R turn signals
2. Handlebar (Description P.16)
3. Brake cable
4. Front reflector
5. Folding hook
6. Scooter folding mechanism
7. Headlight
8. Rear brake light
9. Crutch
10. Front/rear shock absorbers
11. Rear motor
12. Front/rear drum brakes
13. Front mudguard



14. Charging connector

15. Footrest

16. Folding loop

17. Side reflectors

18. Rear mudguard

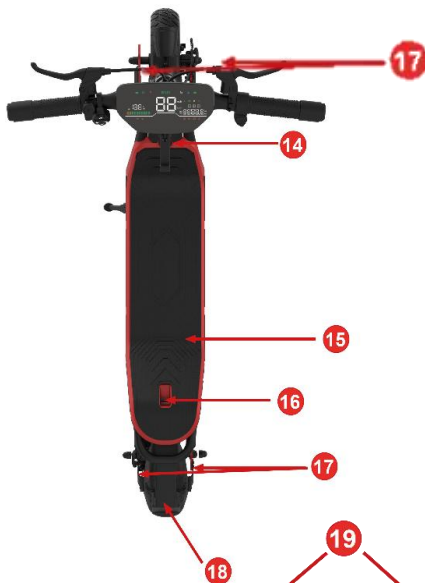

19. Brake handles

20. Accelerator

21. Doorbell

22. Left commodo

(Description p.16)



23.Front headlight indicator on (if icon displayed)

24.Speed indicator in km/h

25.Current Speed Mode Indicator

26.Battery Level Indicator

27.Odometer Indicator

28.ON/OFF button 

29.Headlight switch on (if icon displayed on the screen)

30.Left indicator switch

31.Right indicator switch

32.Speed mode selection switch

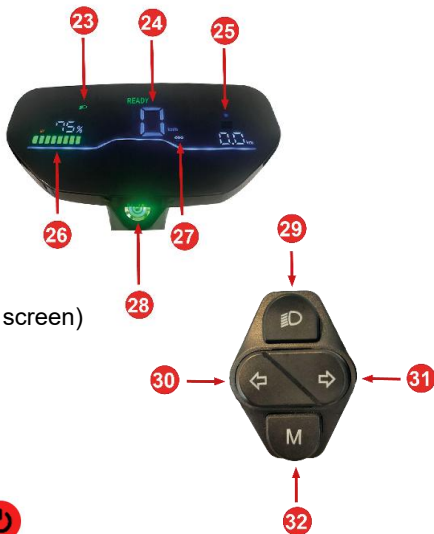

Operating mode of the ON/OFF button 

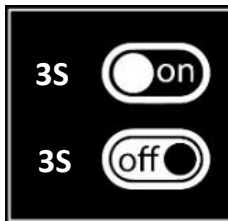

Press 3s (approximately):Start/turn off the scooter



Brief press 7 times: Set and reset password(Attention,this function can only be carried out within 30 seconds after starting your SUVPILOT 150)

Operating mode of the left switch

Brief press 1 time on button:  Turn on/off the front light

Brief press 1 time on button:  Turn the left turn signal on/off

Brief press 1 time on button:  Turn the right turn signal on/off

Support 3s (approximately) on button  Or  : Turn on the hazard lights, then press the button once ← or → for the turn off

Brief press 1 time on button:  Gear ratio change

Brief press 4 times on button:  See the odometer

Long press the button once:  Switch to "Pedestrian speed".

Gear Ratio Selection:

- Gear 1: speed S - maximum 25 km/h
- Gear 2: speed D - maximum 20 km/h
- Gear 3: ECO speed - maximum 15 km/h
- Gear 4: pedestrian speed - maximum 6 km/h (the headlights are automatically switched on)

2.4 Assembling the scooter

1°) Unfold the scooter (unfolding instructions p.19).

2°) Insert the handlebars into the stem tube, being careful not to pinch the cables (this should not force when inserted, and should slide easily). Don't forget to connect the cable between the stem and the handlebars. Orient the handlebars as shown below.

3°) Insert and tighten the six screws (provided) holding the handlebars to the stem using the hex key (provided).

4°) Check that the handlebars do not move in relation to the stem. If the handlebars are still moving relative to the stem, tighten the six screws and recheck if you see any movement between the two.

5°) Check that the tire pressure is between [2 and 2.4 bars] in order to avoid premature mechanical wear of the product (pump not supplied).

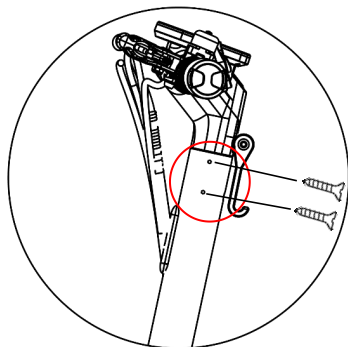

 X6

2.5 Folding the scooter

To fold the scooter, extend the kickstand then

- Press the gray lever (A) while turning the swivel mechanism clockwise (B). Be sure to turn the mechanism all the way down to unlock the descent of the stem.
- (C) Rotate the scooter stem toward the deck
- Carefully lower the stem until the stem hook contacts the deck loop, then be sure to position the hook in the deck loop before lifting the scooter.

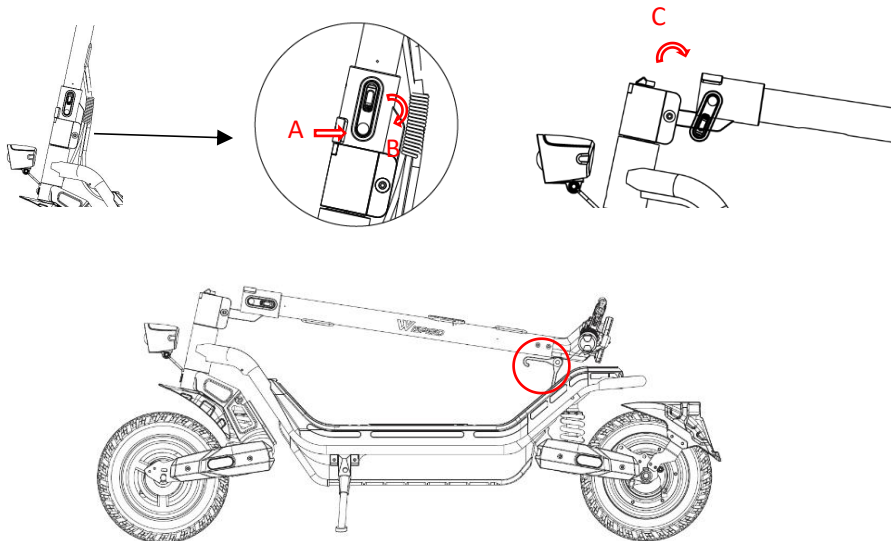

To unfold the scooter:

- Release the stem hook from the deck loop to unfold the scooter.
- (D) Reassemble the stem, making sure to hold the pivot locking mechanism in the down position so that the stem can properly lock in the unfolded position.
- Then lock the unfolding by folding the swivel mechanism counterclockwise until you hear an audible “click” (E)

Remember to always unfold the kickstand and park it on level ground when the scooter is not in use in order to maintain its balance and avoid damage or injury caused by a fall.

The swivel hook on the stem allows you to hold the scooter in the folded position.
CAUTION: Make sure to fold down the stem hook when the scooter is unfolded and in running order.

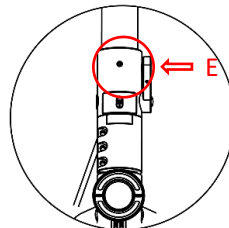
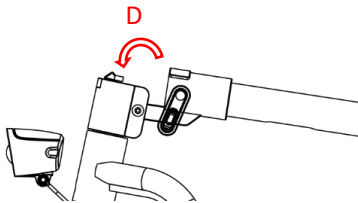

3- Instructions for use

Your experiences riding bicycles, driving automobiles, skiing, and using other similar means of transportation can help you gain better control of your scooter and help you handle your scooter better.

- Before each trip, check that the tires are not damaged or deflated and that no screws on the scooter are loose. If you notice anything abnormal, contact your local dealer.
- Do not make any modifications to the parts on your scooter, as this could reduce its performance, damage it and even possibly cause serious injury to the user or other users.
- When switched on, all the digits will light up. This is a normal situation.

3.1 Weight limitation for users

- There are several reasons for weight limitations:
 1. Guarantee user safety.
 2. Avoid damage to the scooter due to overload.
- Minimum weight: 50 kg.
- Maximum weight: 120 kg.

3.2Autonomy

The range for a full charge can be up to 50km, but varies greatly depending on several factors, such as:

- **Field** :Dry,smooth, flat terrain increases travel distance. Sloping terrain (positive) reduces autonomy.
- **User weight**:The user's body weight has an impact on autonomy. The heavier the user, the less autonomy.
- **Tire inflation**:The recommended pressure range for both tires is [2 to 2.4 bar]. Outside this range, the risk of puncture is higher, mechanical wear of the product is accelerated and autonomy is greatly reduced.
- **Room temperature** :Storing and using your scooter at the recommended temperature can increase battery life. Conversely, use the scooter outside these temperature parameters reduces the latter.
- **Speed and driving habits**:Driving at a constant, low speed increases range. Conversely, frequent starts, stops, accelerations and decelerations reduce the range.
- **Interview** :Having a well-maintained scooter (properly inflated tires, correctly adjusted brake, etc.) preserves autonomy.
- Range, hill capacity and speed may vary depending on user weight, use, temperature and elevation of the route.

3.3 Speed limits

- The maximum speed of thereWISPEED SUVPILOT 150 in S speed is 25 km/h.
- The maximum speed of thereWISPEED SUVPILOT 150 in speed D is 20 km/h.
- The maximum speed of thereWISPEED SUVPILOT 150 in ECO speed is 15 km/h.
- The maximum speed of thereWISPEED SUVPILOT 150 pedestrian speed is 6 km/h.

3.4 Braking

The WISPEED SUVPILOT 150 has two drum brakes, one at the front and one at the rear and a rear electronic brake, which gives it effective braking but must be well controlled.

So pay close attention to the following points:

- To slow down, simply release the accelerator.
- To brake, press a brake handle. The left brake handle controls the rear drum brake and electronic brake. The right brake handle controls the front drum brake and electronic brake. Sudden braking can cause you to become unbalanced and fall; Gradually depress the brake lever to slow down safely. Avoid pressing hard on the brake handle, this will cause braking which could be brutal.
- Do not tighten your brake cable any more than necessary. The rear wheel must not be completely blocked so as not to slip during emergency braking.
- Never touch the brake drums with your fingers



The rear mudguard is not a brake and it is forbidden to press of the knowsto brake. You risk damaging your scooter without being able to lower your speed.

3.5 Light indicators

- **Blinkers** :You must activate the desired turn signal by pressing the corresponding button on the turn signal control located to the left of the handlebars, then press the same button again to remove it. The turn signals do not turn off automatically, press the same button again to turn them off.
- **Rear light**:The rear light (or“brake light”) flasheso muchthat the brake handle is activated. It flashesAlsoas long as you are in pedestrian mode.

4- How to use your scooter

Step 1: Check that the silicone cover covers the charging connector, as well as the overall integrity of your product.

2nd step: Unfold the scooter and press the power button for 3 seconds without touching the accelerator or brake.

Step 3:Check that the kickstand is correctly folded

Step 4: Once the scooter is on, place one foot on the platform and move forward while givingpush off the ground with the other foot without using the accelerator.

Step 5 : You must reach a speed between 3 and 5 km/h to be able to use the accelerator and switch to electric mode. To accelerate, use the “trigger” near your

right hand. You can change the gear ratio by pressing the button 1 time **M**

Step 6: To brake, use the brake handles located on each side of the handlebars.

Step 7: To turn off your scooter, press the power button for 5 seconds.

IMPORTANT:

- **To avoid any danger, sudden turns should always be avoided when traveling at high speed.**

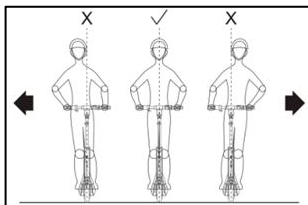

Ideal position to adopt for riding in complete safety.

5- Battery use and charging

This section covers the charging method, battery maintenance, safety points and battery specifications. To ensure your safety and that of others, increase battery life and performance, handle and use the battery as following.

WARNING !:

Do not use your scooter when the battery is low or the system requests a safe shutdown. Battery life will be reduced if you continue to use there WISPEED SUVPILOT 150 while the battery level is low.

5.1 Battery charging

When the battery level on the control screen appears red and flashes, it means that the voltage is low and the scooter will not sufficiently be supplied with current to drive normally. Stop, as this may cause instability as well as shorten battery life. It is strongly recommended to charge your scooter when the battery level is at 15% or below.

To charge your battery, please follow the following steps:

- Check that the charging connector on the tray is dry.
- Connect the supplied mains charger to the scooter via this connector
- Plug the mains charger into a mains socket.
- If the charger light lights up red on the charging pad, this means that the battery is charging correctly. If the light is green, check that the cable is correctly connected to the scooter.
- Full charging of the WISPEED SUVPILOT 150 takes approximately 8 hours.
- When the charger light changes from red to green, charging is complete.
- Unplug the mains cable then from the scooter side.

IMPORTANT:

- Charging for too long may shorten battery life.. Do not leave your scooter plugged into the charger overnight.
- Be sure to fully recharge your scooter's battery each time you recharge it to maximize its lifespan.

- Keep the charging environment clean and dry.
- Do not charge the battery if the charging socket is wet or damp.

WARNING !:





The scooter cannot turn on when plugged into the mains.

5.2 Battery characteristics

Battery Model	JT-ESB10-05
Battery Type	Lithium ion
Loading time	Around 8 hours
Nominal voltage	36V
Ability	15.6 Ah

6- Error codes

If a malfunction occurs while using your WISPEEDSUVPILOT 150, you will then see one of the following error codes appear on the screen:

CODED	Screen icon	MEANING	APPEARANCE WHEN SWITCHING ON	APPEARANCE IN OPERATION
E6	/	Engine overheating	Return after-sales service	Shutdown – Waiting for cooling
E8		Over or under voltage anomaly	Return after-sales service	Stop – Return after-sales service
E10		Communication anomaly	Return after-sales service	Stop – Return after-sales service
E11	ECU	Controller fault	Return after-sales service	Stop – Return after-sales service
E14		Accelerator fault	Return after-sales service	Stop – Return after-sales service
E15		Brake malfunction	Return after-sales service	Stop – Return after-sales service
E16		Hall sensor anomaly	Return after-sales service	Stop – Return after-sales service

If the problem persists, go to the Urban sliding section and the Assistance section of our website: www.wispeed.net

7- Maintenance and storage

Your Scooter requires regular maintenance. The following steps describe the important steps and requirements associated with its maintenance

7.1Cleaning

- Check that the power supply and charging cable of your scooter have been unplugged.
- Clean your scooter with a soft, dry cloth.

WARNING!

Your WISPEED SUVPILOT 150 is IPX5 certified. This means that it is splash-proof. However, it should not be submerged or subjected to a jet of water. So never clean there WISPEED SUVPILOT 150 with high pressure water jets and never immerse it in any liquid. Prevent water or other liquids from entering the WISPEED SUVPILOT 150, as this may cause irreversible damage to electronic components. Your product would then be excluded from the warranty.

7.2 Storage

- Before storage, fully charge your scooter to prevent excessive battery discharge due to prolonged non-use.
- Before storage, fully charge your scooter to prevent excessive battery discharge due to prolonged non-use.
- If the scooter is stored for several months, remember to recharge it at least once (8 hours) every three months. Otherwise, the warranty will not take effect for such negligence.
- Do not charge the battery if the temperature is below 0°C. Place your scooter in a warmer environment (more than 10°C) before charging. Do not charge your battery if the ambient temperature is above 40°C.
- You must protect your scooter to avoid a deterioration in its performance due to dust. Store your scooter indoors, in a dry place, at an appropriate temperature (between 15°C and 30°C).

7.3 Condition of tires

- Check the front and rear wheels and hub carefully before using the scooter. Tires must not be damaged, deflated or punctured.
- In case of underinflated tires, use a bicycle pump to which you adapt the inflation nozzle provided.
- Check the condition of your tires every 2/3 weeks of use.

- If you see the wear marks below on your tires, please change your tires.



- In the event of excessive wear, you can order new tires via our site <https://www.wispeed.net/assistance> section or contact the after-sales service to replace the tires.

7.4 Maintenance

- **7.4.1 Maintenance of the braking system:**

Your drum brakes are adjusted at the factory, if you wish to change this setting, contact a professional.

- **7.4.2 Maintenance of screws:**

Carefully check the screws of each part before using the scooter. The screws must not be loose or too damaged.

Noticed: Check that the scooter is operating normally before each use. In the event of an anomaly, do not use it and contact after-sales service to have it repaired. Never modify the structure of the scooter. Any modification may result in a risk of injury, and the manufacturer will not be liable for any damage resulting from such modification.

WARNING!

- To ensure your safety and that of others, never disassemble your scooter, do not divert it from its initial use, otherwise your warranty will be voided.

7.5 Assistance

Our website <https://www.wispeed.net/can> provide you with various supports via the assistance section.

- A list of photo tutorials that detail the maintenance process or replacing a tire in more detail.

- Technical support via the dedicated email address gls_urbaine@logicom-europe.com
- A FAQ dedicated to your product
- The possibility of ordering different elements (a second charger, an inflation nozzle, a tire) (*)

() The list of items available for sale is subject to change. Logicom reserves the right to modify without notice or justification all or part of this list, or even to suspend the sale of these elements at any time without this being considered as prejudice to the user.*

8- Lock

How the lock code works:

Your scooter has an electronic lock, deactivated by default.

WARNING:

- In order to activate the electronic lock, the entire procedure below must be completed within 30 seconds that follow ignition. HAS default, it will be necessary to restart the scooter to start again.



- To activate the lock you must:

Turn on your scooter by pressing the start button  for approximately 3 seconds, you will hear a beep and the display will be on.

2- Your scooter is on. To activate the lock code, quickly press the start button 7 times .

3- the default code is 00. To enter the numbers Use the brake to scroll the left digit and the throttle trigger to scroll the right digit. Then validate by pressing the power button twice in a row . To define your personalized password, change the code of your scooter.

How to change the scooter code:



To change your code, unlock your scooter. Then press the start button 7 times . Then type your active code (for the first change the active code is 00). To enter your digits, use the brake to scroll to the left digit and the throttle trigger to scroll to the right digit. Then validate (press the button twice in a row  to validate).

You will be asked for a second entry to define a new code, once chosen, validate (press the button twice in a row  to validate).

Enter the unlock code for your scooter below:

--	--

Now that the code lock is activated, each time you start it, your scooter will ask you for your code (two digits).

To unlock the scooter, turn it on by pressing  3 seconds, then enter your code, then press twice .

Disable passcode lock.

To deactivate the code, unlock your scooter. Then press the start button 7 times . Then type your code once. You will be asked for a second entry, instead of entering a new code (you have the choice to change the code by entering a new code or to deactivate the password) squeeze the brake handle until you hear a “Beep” to deactivate the code.

ATTENTION !If you deactivate your code, the default code will be your old code.

The scooter turns off by itself and locks (if the code is activated) after 5minutes of inactivity.

9 – Odometer

By turning on the scooter, the scooter displays the number of kilometers traveled during this session of use.

By pressing the M button 4 times, you can view the total number of kilometers traveled.

Just wait about 3 seconds and the display returns to your session screen.

10- Technical informations

Name	Settings
Net weight	29kg
Minimum load	50kg
Maximum charge	120kg
Maximum speed	25 km/h
Maximum autonomy	Up to 50km (depending on terrain, driving habits and load)
Maximum angle of climb	20%
Power supply	Lithium-ion battery
Nominal power	500W (0.50kW)
PowerMaximum	800W (0.80kW)
Rated capacity	561.6 Wh

Dimensions (L*W*H)	1280*620*1280mm
Battery	36V/15.6Ah
Operating temperature	Min=0°C, Max=45°C
Maximum tire pressure	2.4 Bar
Minimum tire pressure	2 Bar
Weighted sound pressure level	<70dB(A)

The total value of vibrations to which the hand-arm system is exposed does not exceed 2.5 m/s²

11- EU declaration of conformity

We, LOGICOM SA – 55 rue de Lisbonne – 75008 PARIS,
declare that the product

Brand: WISPEED

Trade name : **SUVPILOT 150**

Type: Electric Scooter (PLEV Class 2)



To which this simplified declaration refers, it complies with the essential requirements and other relevant provisions of the Machinery Regulation (2006/42/EC) and the EMC Directive (2014/30/EU).

RM	ISO 12100:2010; EN 17128:2020
EMC	EN 17128:2020

As well as the essential requirements of the RoHS Directive (2011/65/EU), the ErP Directive (2009/125/EC) and the REACH Regulation (1907/2006).

RoHS	IEC 62321-3-1:2013 – IEC 62321-4:2013+A1:2017 – IEC 62321-5:2013 – IEC 62321-6:2015 – IEC 62321-7-2:2017
REACH	Regulation No. 1907/2006

The full text of the EU declaration of conformity is available at the following internet address:

<https://www.logicom-europe.com/ce-doc>

11- Charger information

V03TB

Manufacturer name and address	JIANGXI FU DIAN YOU PIN TECHNOLOGY CO.,LTD (Innovation and entrepreneurship park, Economic Development zone, Guixi City Jiangxi Province, CHINA)
Model reference	FY-4202000
Input voltage	100-240V
Input alternating current (AC) frequency	50-60Hz
Output voltage	42V
Output current	2A
Output power	84W
Average yield in active mode	>88%
Power consumption without load	<0.21W

13- Recycling



The symbol shown here and on the device means that the device is classified as electrical or electronic equipment and should not be disposed of with other household or commercial waste at the end of its life.

The WEEE Directive 2012/19/EU (Waste Electrical and Electronic Equipment Directive) was introduced to recycle devices using the most efficient recovery and recycling techniques to minimize the impact on the environment. environment, treat dangerous substances and avoid increasing landfills.

Disposal instructions for private users:

When you no longer use the device, dispose of it according to local recycling processes. For further information, contact your local authorities or the retailer of the device.

Disposal instructions for professional users:

Business users should contact their suppliers, check the terms and conditions of the purchase contract and ensure that this device is not mixed with other commercial waste when discarded.

14- Scope of warranty

In case of problems :

A contact form as well as a complete FAQ are available in the Support section of our website:<https://www.wispeed.net/fr/>

If none of these platforms have solved your problem, please contact your reseller (with your product and its charger).

For safety reasons, only our technical station is authorized to work on our products, with this in mind we do not provide any spare parts.

The LOGICOM supplier warranty is valid for normal use of the product as defined in the user manual for a period of 2 years on the product and 1 year for the battery.

Excluded from this guarantee is damage due to a cause unrelated to the device.

In particular, the warranty does not apply if the device has been damaged as a result of a shock or a fall, a wrong operation, a connection not in accordance with the instructions mentioned in the instructions, the effect of lightning, mains overvoltage, insufficient protection against heat, humidity or frost.

The warranty only extends to Metropolitan France.

- Installing solid tires on your scooter will result in a total and definitive exclusion of the warranty.
- The warranty does not cover the user manual.
- The warranty does not cover normal wear and tear of the product (brakes, battery, tires, wear of the deck, wear of the mudguard, wear of the plastic protective covers, etc.)
- The warranty does not cover any deterioration of the product due to misuse, including in particular those caused by collisions with objects or a fall.
- The warranty does not cover any use of the product that does not comply with the precautions for use stipulated in the user manual.
- The warranty does not cover defects caused to the product by an accessory not supplied by WISPEED.
- The warranty does not cover any damage caused to the battery.

- The warranty does not cover the product or its accessories if it has been disassembled or modified in any way.
- The warranty does not cover any product not identifiable by its serial number. If elements have been removed, erased, modified or made illegible, the warranty does not apply.
- The warranty does not cover damage to the product following exposure to humidity, extreme heat or cold conditions, corrosion, oxidation, or any liquid whatsoever.
- The warranty does not cover any deformation, damage or breakage of the main frame following a sudden fall, excessive overload or repeated shocks.
- The warranty does not cover any forgetting or error in handling the unlocking code..

In any event, the legal guarantee for hidden defects will apply in accordance with articles 1641 et seq. of the Civil Code and L.211-1 et seq. of the Consumer Code..

Made in the PRC © 2024 Logicom SA.

W ***ISPEED***